

Propeller Pump Series ALLPRO® PPR and PGE/PGF

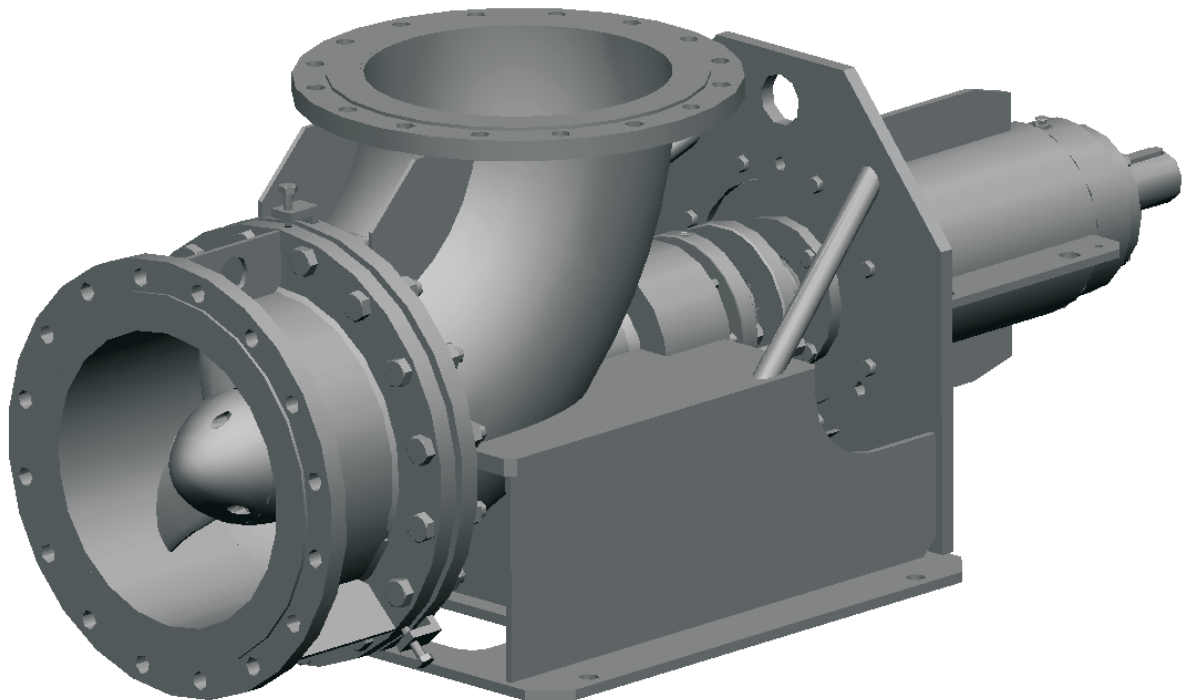

Utilization

Designed to circulate or accelerate chemically aggressive or non-aggressive liquids; clear liquids or liquids containing solids; hot or cold liquids.

Main fields of application

- Used in wastewater and clarification engineering as recirculation pumps to return nitrate-laden wastewater or activated sludge from nitrification basins into denitrification basins. Also used in wastewater and clarification engineering to circulate or accelerate other liquids appropriate for propeller pumps.
- Used in the chemical industry/process engineering as acceleration pumps in reactor closed loops and as circulation pumps in acid baths or crystallization systems.
- Employed as circulation pumps in desalination plants for production of drinking water and salt extraction.
- In the cellulose industry as acceleration and mixing pumps.
- As circulation pumps in evaporation plants (such as for REA wastewater or acid processing) and in concentration systems.
- In the food industry, such as circulation pump in bottle rinsing machines.
- Cooling water supply for drive turbines on ships.
- Biogas plants.

Performance data ①②

	PGE/PGF	PPR
Delivery flow	Q up to 11,500 m ³ /h	up to 50,000 m ³ /h
Delivery head	H up to 8,5 m	up to 12 m
Discharge pressure ③	p _d up to 6 bar	up to 6 bar
Liquid temperature	t up to 200 °C	up to 200 °C
Delivery branch nominal width	Dn _d 200-700	200-1.200

① Pumps for other specifications upon request.

② The specified operation limits are maximum values. Actual values may be lower in individual cases depending on technical variations. Refer to the respective order documentation for binding values.

③ Inlet pressure plus maximum delivery head may not exceed the permissible discharge pressure.

Pump series

The PPR series utilizes a pump casing made from non-castable materials.
The PGE/PGF series is used for cast materials.

Design

Single-stage propeller pump with dry installation.
The cast or welded pump casing is in the form of a elbow pipe. Depending on the required delivery head, the propeller is equipped with three or more blades.

They are three-dimensionally curved, hydraulically optimized, and insensitive to contamination. Specially designed fiber-deflecting blade shapes are available for liquids with fibrous components.

The pump casing can be equipped with an exchangeable wear ring or intermediate piece in the impeller area of the propeller. The pump has a torsion-proof shaft that ensures smooth running up to the operational limits specified in the individual curves. The torsion-proofness and short distance between the pump-side bearing and shaft seal result in high truth of running for optimal shaft sealing conditions.

The shaft is protected by an exchangeable shaft sleeve in the shaft seal region.

The pumps are installed horizontally or vertically and are also capable of pumping in the opposite direction.

Abbreviation

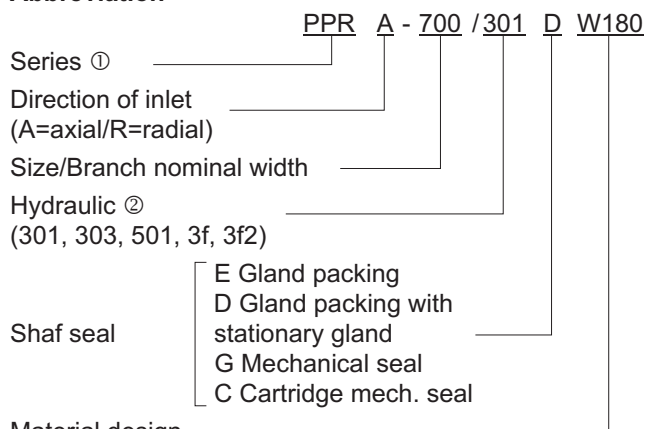

- ① PGE: Cast version, inserted into pipe
- PGF: Cast version, installed on foundation
- PPR: Welded version, inserted into pipe or installed on foundation

② 3f and 3f2 available only for PGE/PGF

Flansche

- Flanges PGE/PGF: - Cast/stainless steel acc. to DIN EN 1092-1 PN10/21/B1
- Cast iron
- DIN EN 1092-2 PN10/21/B
- Flanges PPR: - Up to size 800
- DIN EN 1092-1 PN 10/11/B1
- Size 900 DIN 28036 and larger

Shaft sealing

A variety of alternatives are available for sealing the shaft, such as gland packing, mechanical seals, or cartridge seals. Refer to pages 4 and 5 for sealing variations.

Material code

Denomination	Material design ②						
	W180		W181		W182	W183	
Series	PGE/PGF	PPR	PGE/PPF	PPR	PGE/PGF	PGE/PGF	PPR
Pump casing	EN-GJL 250	St 37	1.4408	1.4571 ①	1.4517	1.4529 ①	
Shaft	1.4571		1.4571		1.4462	1.4529	
Propeller	1.4408 / 1.4571		1.4408 / 1.4571		1.4517 / 1.4462		1.4529
Bearing bracket	EN-GJL 250	St 37	EN-GJL 250	St 37	EN-GJL 250	EN-GJL 250	St 37

① only parts contacting liquid

② other materials available as special order (WX)

The gland packing version of the PPR series is delivered with a stationary gland packing as standard equipment. As a result, it is not necessary to empty the system when exchanging the seal. This variation is available as an option on the PGE/PGF series.

Bearing and lubrication

The shaft bearing is in a bearing bracket in grease-lubricated antifriction bearings ①. The bearings are designed for a service life of at least 25,000 operating hours.

- ① PGE/PGF up to size 400: Lifetime grease-lubricated antifriction bearing. Antifriction bearing with regreasing capability available as an option. PGE/PGF sizes >400 and PPR all sizes: Regreasable antifriction bearing as standard.

Installation and mounting

The pumps are installed horizontally or vertically in a flood-safe area. The following mounting variations are available as standard products:

PGE/ PPR Pump installed horizontally or vertically directly in the pipe, without foundation. Depending on the weight of the motor, the drive may be flanged directly onto the bearing bracket via a motor bracket. When higher-output drives are used, the drive must utilize a V-belt (motor attached to the bearing bracket via a rocker) or universal joint shaft (motor set up separately).

PGF/ PPR Horizontal pump mounting on foundation. Drive power transmitted via directly-coupled motor or via gear box/V-belt.

Other installation/mounting styles available upon request.

Drive

With constant-speed electric motors or speed adjustment through gear box/belt drive or pole-changing or frequency-regulated electric motors. Speed-regulated drives allow the pump to properly react to alternating capacities without efficiency losses.

Explosion protection

 The pump fulfills the requirements according to EU explosion-protection directive 94/9/EC (ATEX 100a) for devices in device class II, category 2 G. Classification into temperature classes according to EN 13463-1 depends on the temperature of the pumped liquid. Refer to the proposal or order documentation for the maximum permissible liquid temperature for the respective temperature classes.

Note: When operating the pump in category 2, suitable measures must be provided to prevent impermissible warming of the pump surfaces in the event of disturbance.

Performance graphs

Valid for $\rho = 1 \text{ kg/dm}^3$ and $\nu = 1 \text{ mm}^2/\text{s}$

Hydraulics:
301, 303, 501

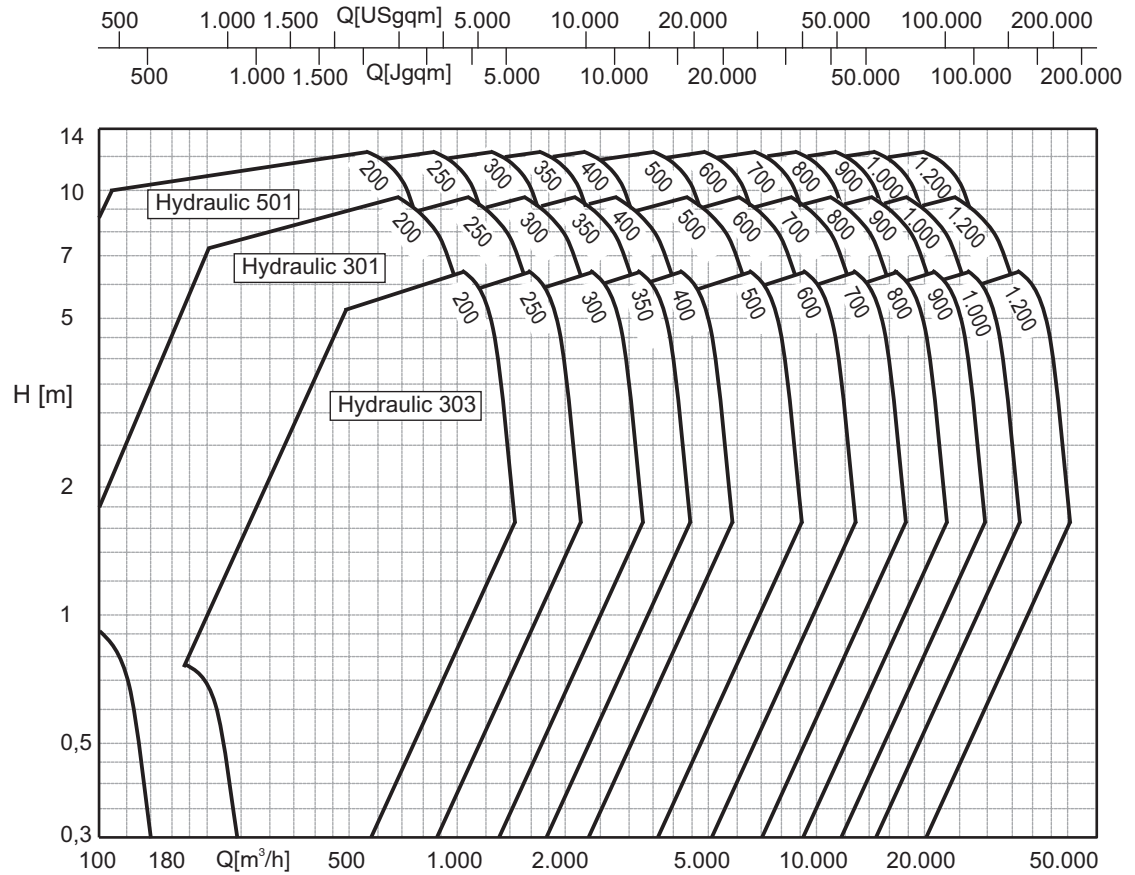

Hydraulic: 3f

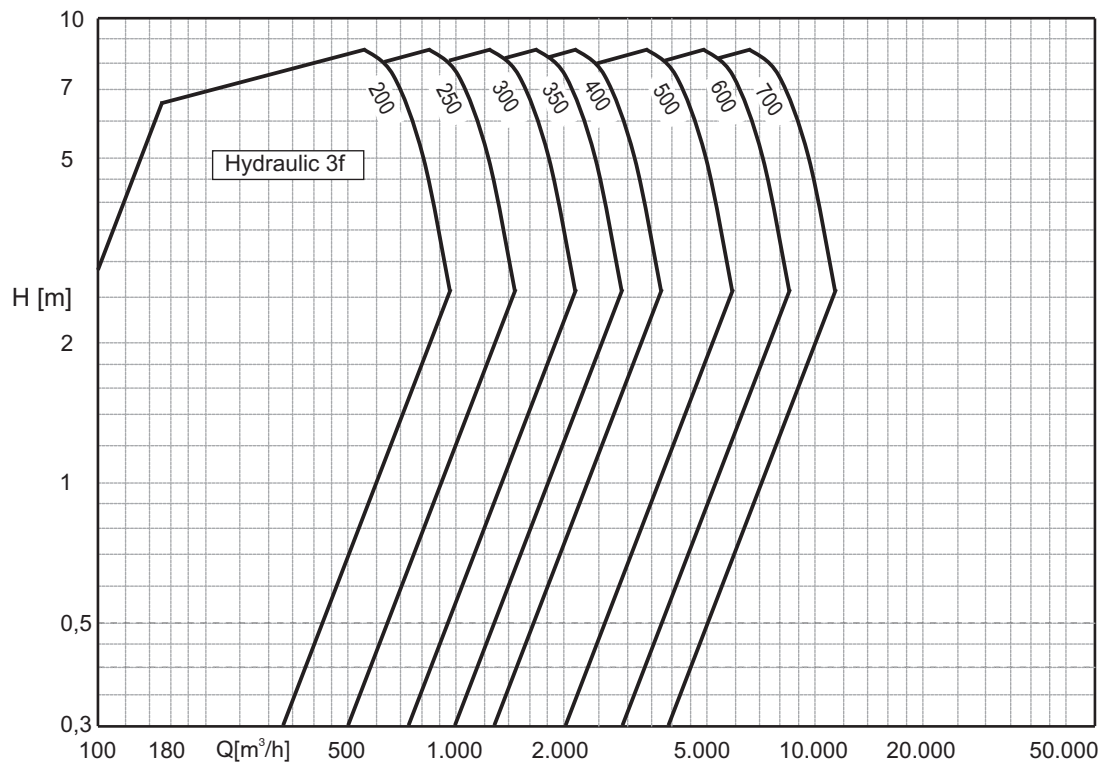

Note: 3f2 hydraulics for wastewater treatment, blade angle up to 18°

Overall performance range per size in consideration of all permissible speeds.
Refer to the individual curves for precise performance data.

Assembly PPR

Basic version, shaft sealed with gland packing with stationary gland, shaft bearing grease lubricated.

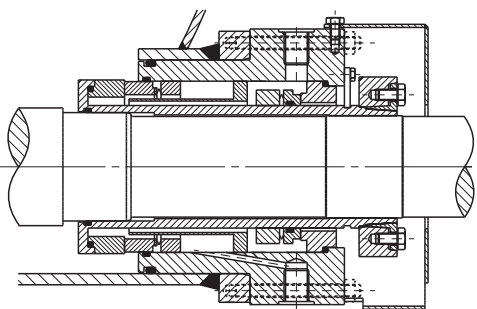
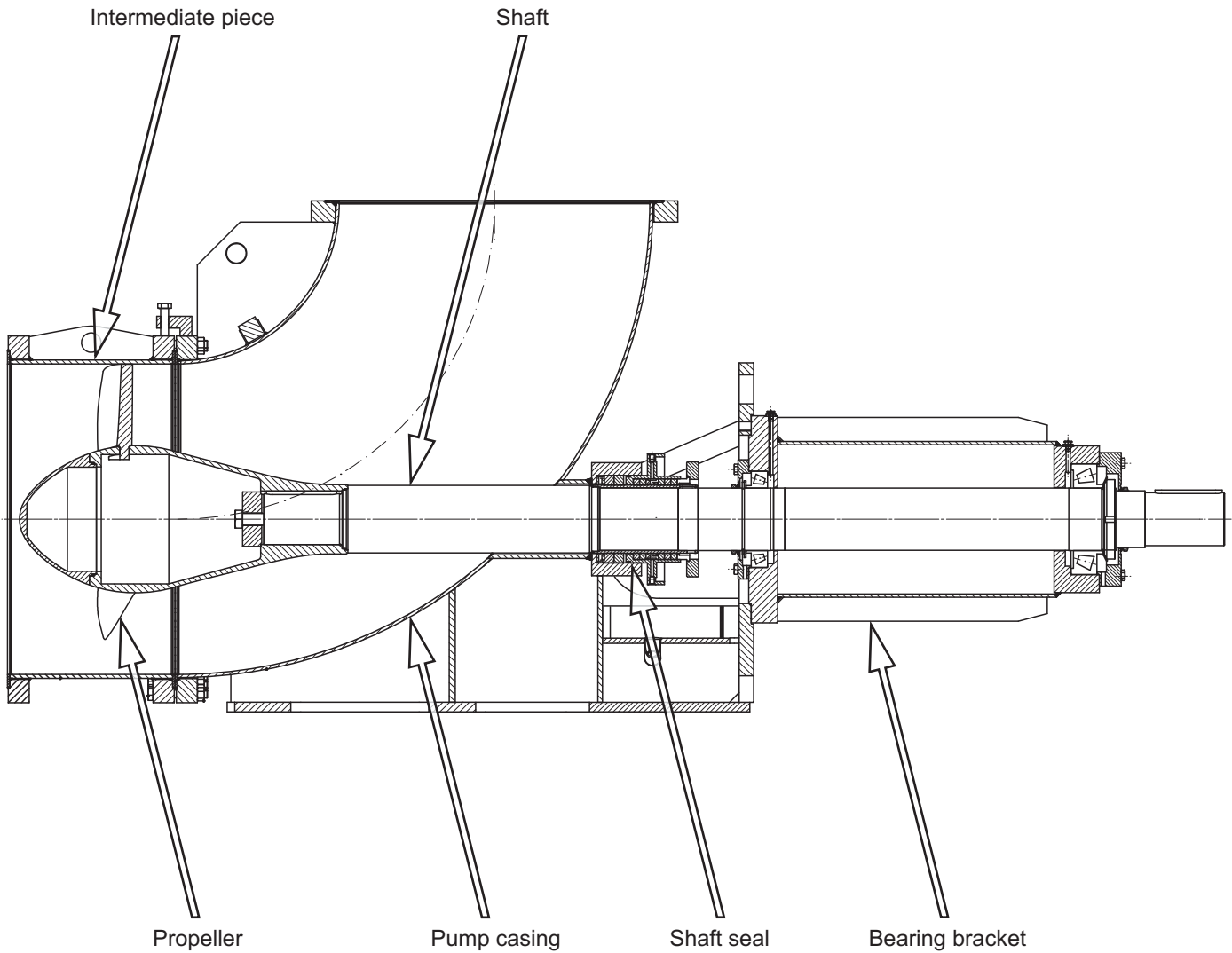

Cartridge-type shaft sealing (single or multiple mechanical seals)

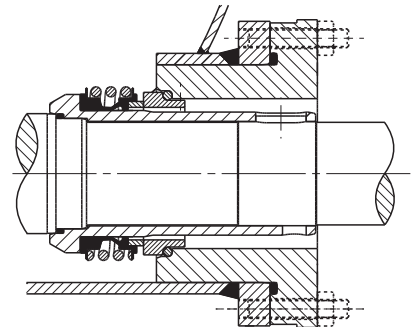

Shaft sealed with single mechanical seal

Assembly PGE/PGF

Basic version (cast), shaft sealed with gland packing, shaft bearing grease lubricated.

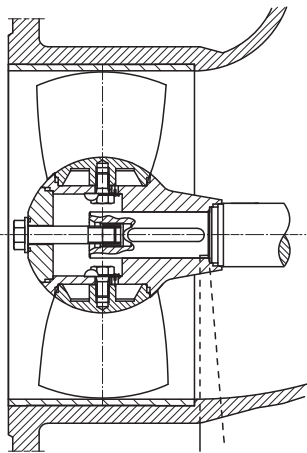
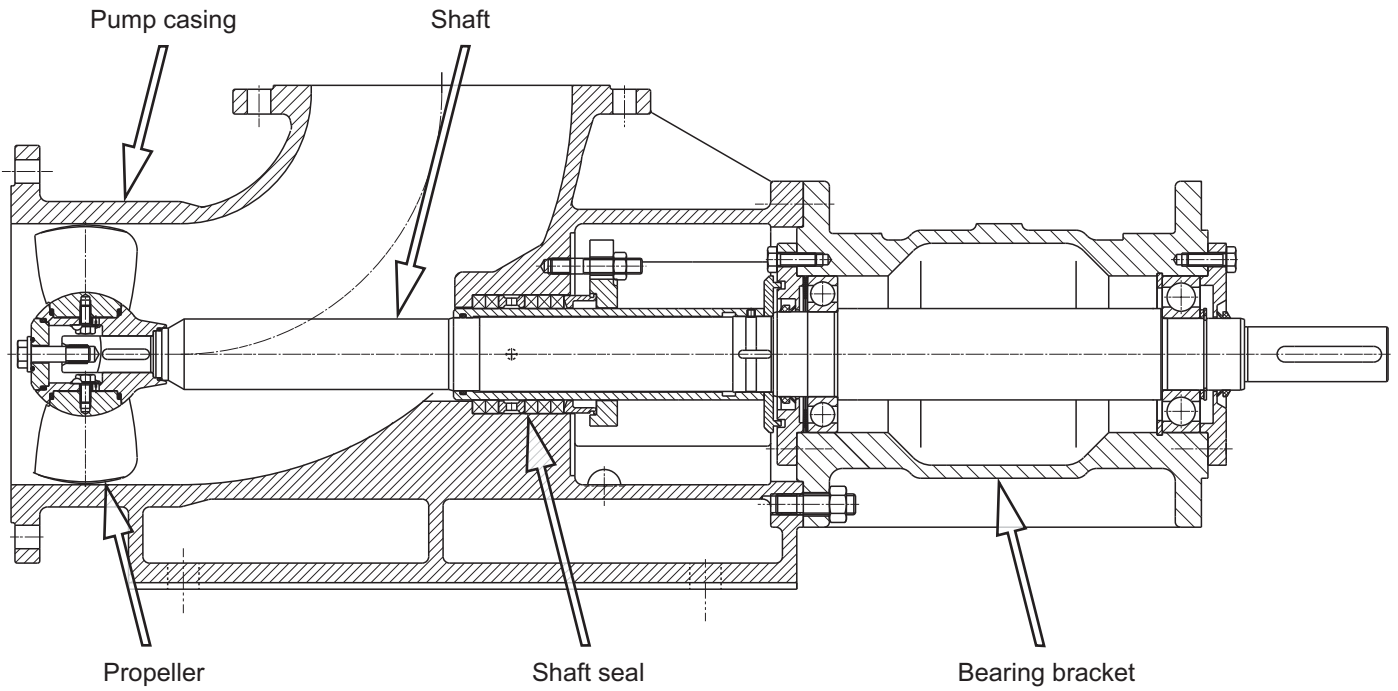

Wear-ring version

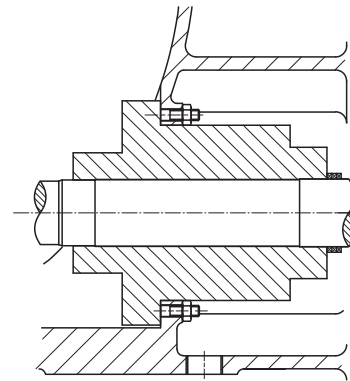

Cartridge-type shaft sealing (single or multiple mechanical seals)

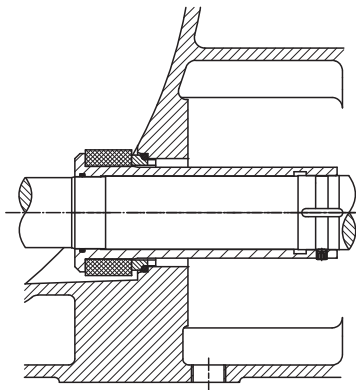

Shaft sealed with single mechanical seal

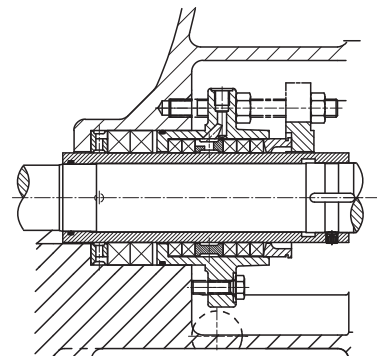

Shaft sealed with gland packing with stationary gland

Main dimensions PPR

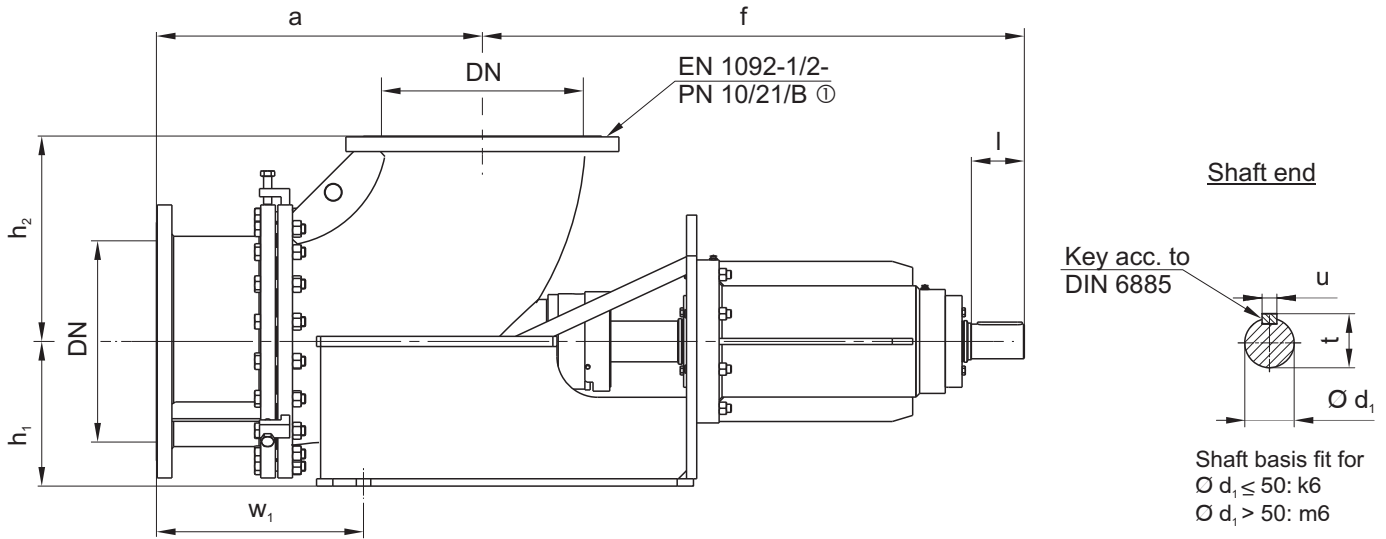

Pump foot for sizes (200 up to 350)

(400 up to 600)

(700 up to 1000)

(1200)

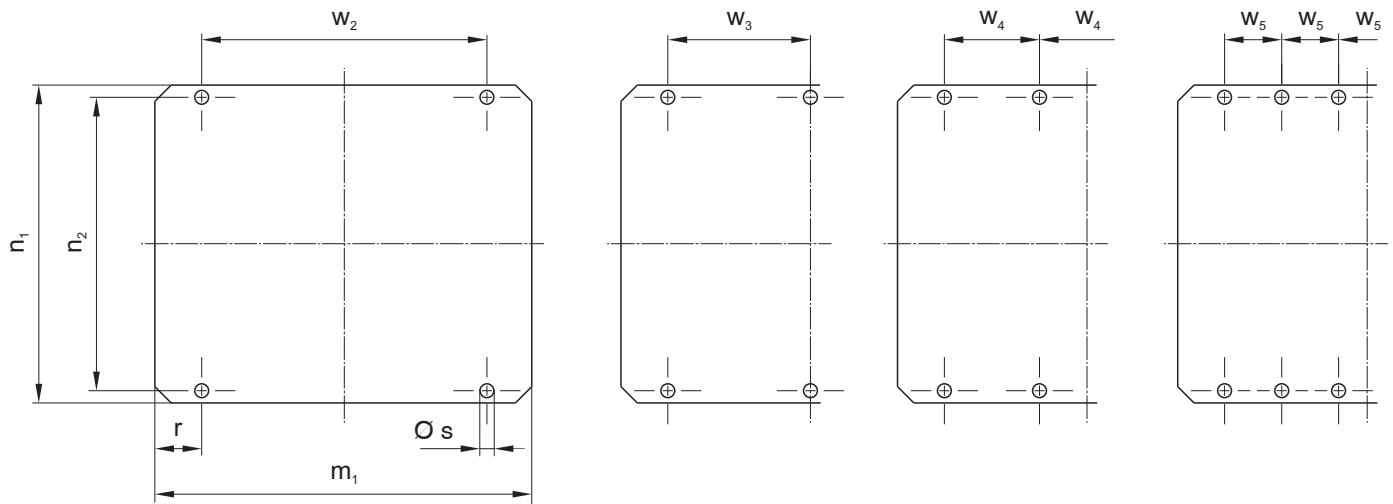

① Size 900 and larger DIN 28036

Dimensions in mm.

PPR	Pump dimensions								Foot dimensions							Shaft end			
	DN	a	f	h ₁	h ₂	m ₁	n ₁	n ₂	w ₁	w ₂	w ₃	w ₄	w ₅	r	s	d ₁	l	t	u
200	200	340	900	190	200	520	470	424	275	355	-	-	-	75	23	38	58	41	10
250	250	400	970	212	250	565	498	452	306	400	-	-	-	75	23	50	82	53,5	14
300	300	490	1050	245	301	650	580	534	350	485	-	-	-	75	23	50	82	53,5	14
350	350	560	1025	265	352	695	620	574	375	520	-	-	-	85	23	60	105	64	18
400	400	630	1190	300	402	787	680	620	431	-	280	-	-	112	28	75	105	79,5	20
500	500	800	1330	355	504	925	780	720	508	-	350	-	-	115	34	85	130	90	22
600	600	950	1530	400	606	1037	914	852	533	-	420	-	-	77	34	110	165	116	28
700	700	1120	1705	475	707	1180	874	934	676	-	-	298	-	143	34	120	165	127	32
800	800	1244	1845	530	813	1335	1135	1035	730	-	-	340	-	172	34	130	200	137	32
900	900	1374	1900	560	919	1390	1174	1104	752	-	-	360	-	160	41	140	200	148	36
1000	1000	1550	2095	630	1021	1583	1355	1275	877	-	-	420	-	163	41	150	200	158	36
1200	1200	1850	2420	740	1225	1825	1580	1500	980	-	-	-	300	163	41	180	240	190	45

Main dimensions PGE/PGF
Size 200 and 250

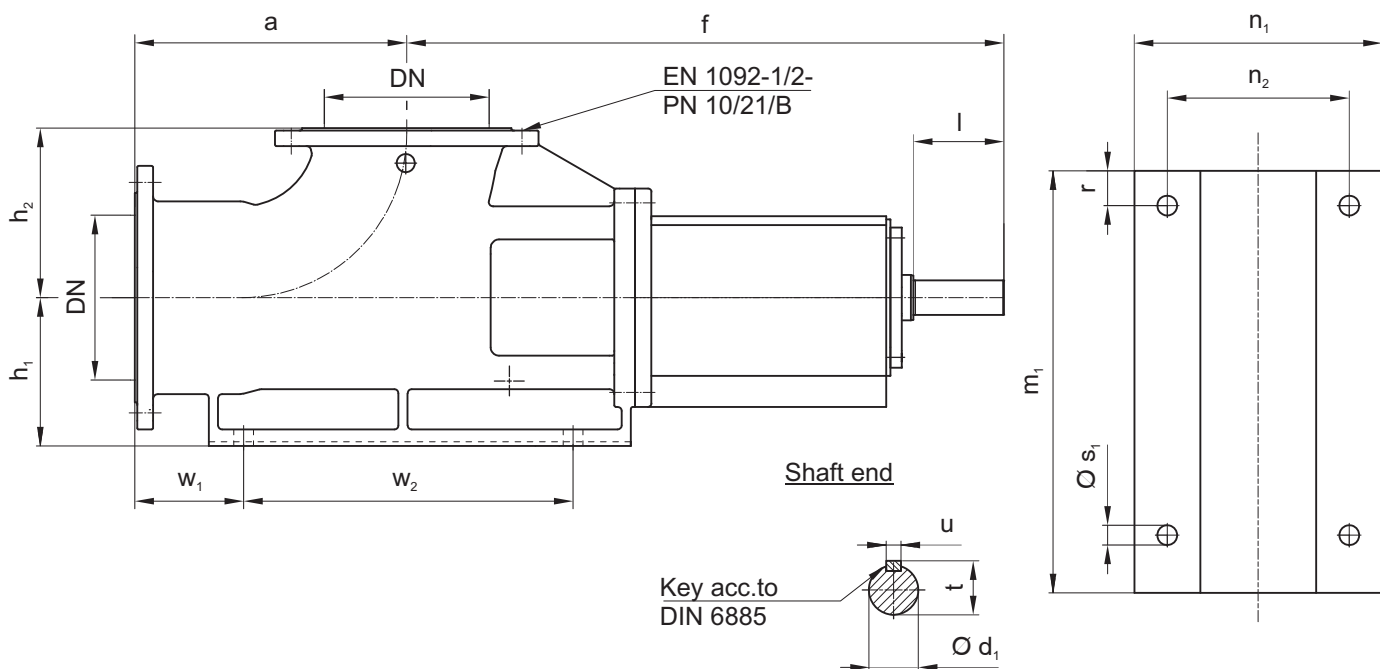

PGF size 300 and larger (PGE without Pump foot)

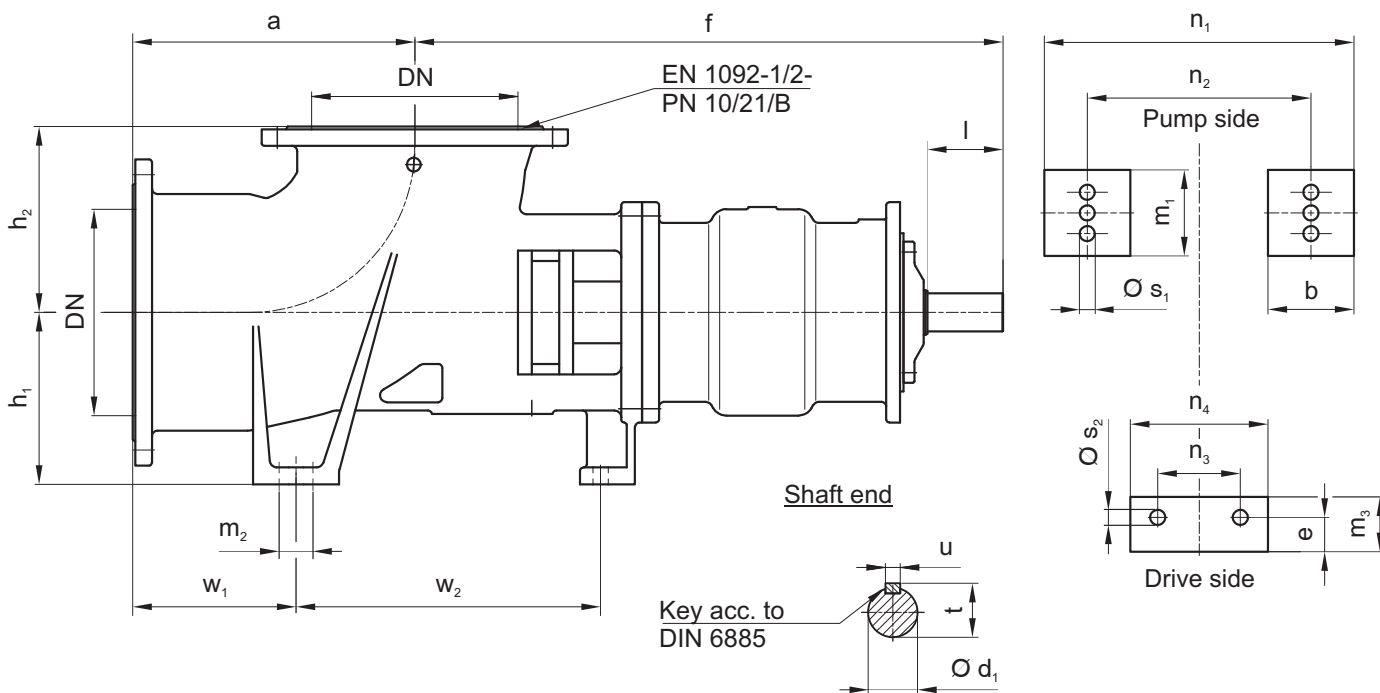

Dimensions in mm.

PGE/ PGF	Pump dimensions					Foot dimensions										Shaft end							
	DN	a	f	h ₁	h ₂	b	e	m ₁	m ₂	m ₃	n ₁	n ₂	n ₃	n ₄	r	w ₁	w ₂	s ₁	s ₂	d ₁	l	t	u
200	200	330	725	180	206	-	-	512	-	-	300	220	-	-	42	132	400	24	-	42	110	45	12
250	250	410	825	225	257	-	-	590	-	-	375	285	-	-	45	165	500	24	-	42	110	45	12
300	300	410	855	250	270	125	50	125	-	80	450	325	120	200	62,5	237,5	442,5	22	22	55	110	59	16
350	350	480	875	280	310	125	50	125	-	80	500	375	120	200	62,5	262,5	507,5	24	24	55	110	59	16
400	400	530	835	315	350	150	60	150	-	100	550	400	170	250	75	315	455	24	24	55	110	59	16
500	500	650	1040	355	440	150	60	200	-	100	650	500	170	250	100	375	605	26	26	70	140	74,5	20
600	600	750	1240	425	520	150	70	200	-	120	750	600	200	300	100	400	730	26	26	85	170	90	22
700	700	860	1380	475	600	175	70	250	125	120	850	675	200	300	62,5	475	805	26	26	85	170	90	22

Mounting

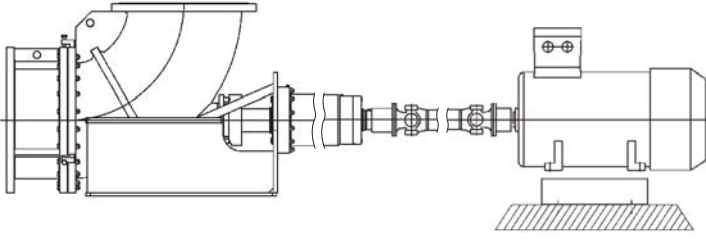

Propeller pump inserted into pipe, motor on separate base plate, drive via universal joint.

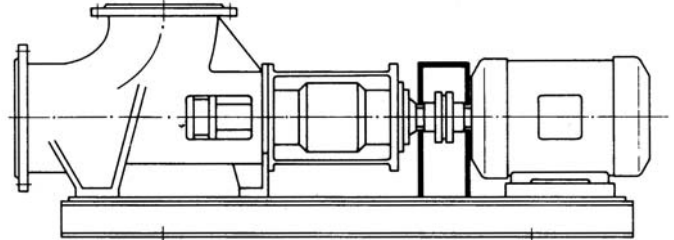

Propeller pump with directly-coupled drive motor, horizontally mounted, on shared base plate.

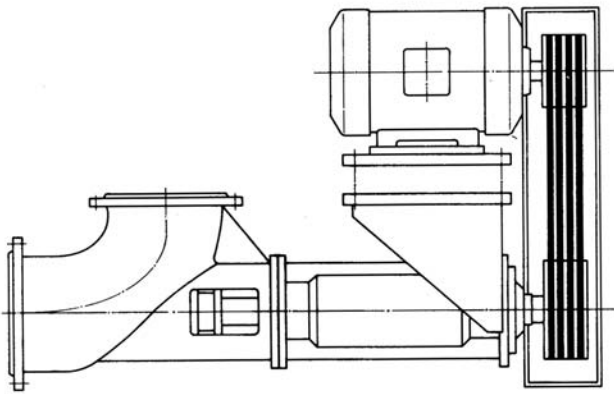

Propeller pump inserted into pipe. Motor on rocker, fastened onto pump bearing bracket (above or below), drive via V-belt.

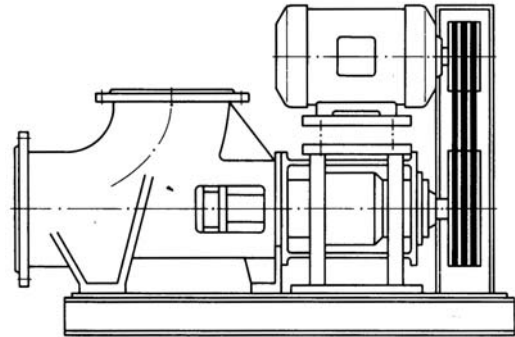

Propeller pump installed horizontally on base plate, motor aligned above bearing bracket, drive via V-belt.

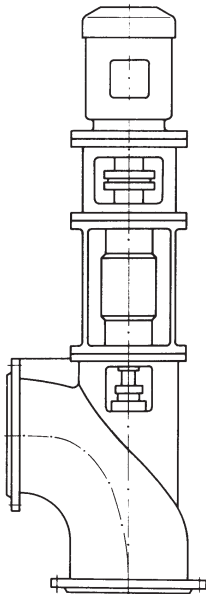

Propeller pump with directly-coupled drive motor inserted horizontally or vertically in the pipe.

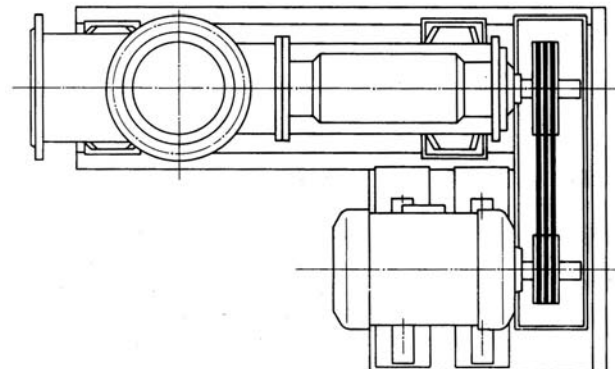
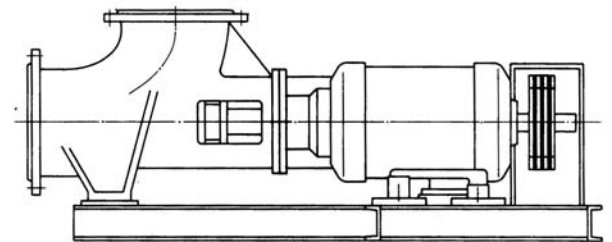

Propeller pump installed horizontally, motor to the side on shared base plate, drive via V-belt.

Benefits PPR

► **High efficiency**
through a flow-optimized
propeller head.

► **Economical**
with high efficiency across
a wide capacity range.

► **Process optimized**
through a special torsion-
proof shaft in conjunction
with a tolerance-free
adjustable bearing that
ensures high truth-of-
running and therefore
optimal conditions for the
shaft seal.

► **Affordable**
thanks to exchangeable
intermediate piece when
abrasive liquids cause wear.

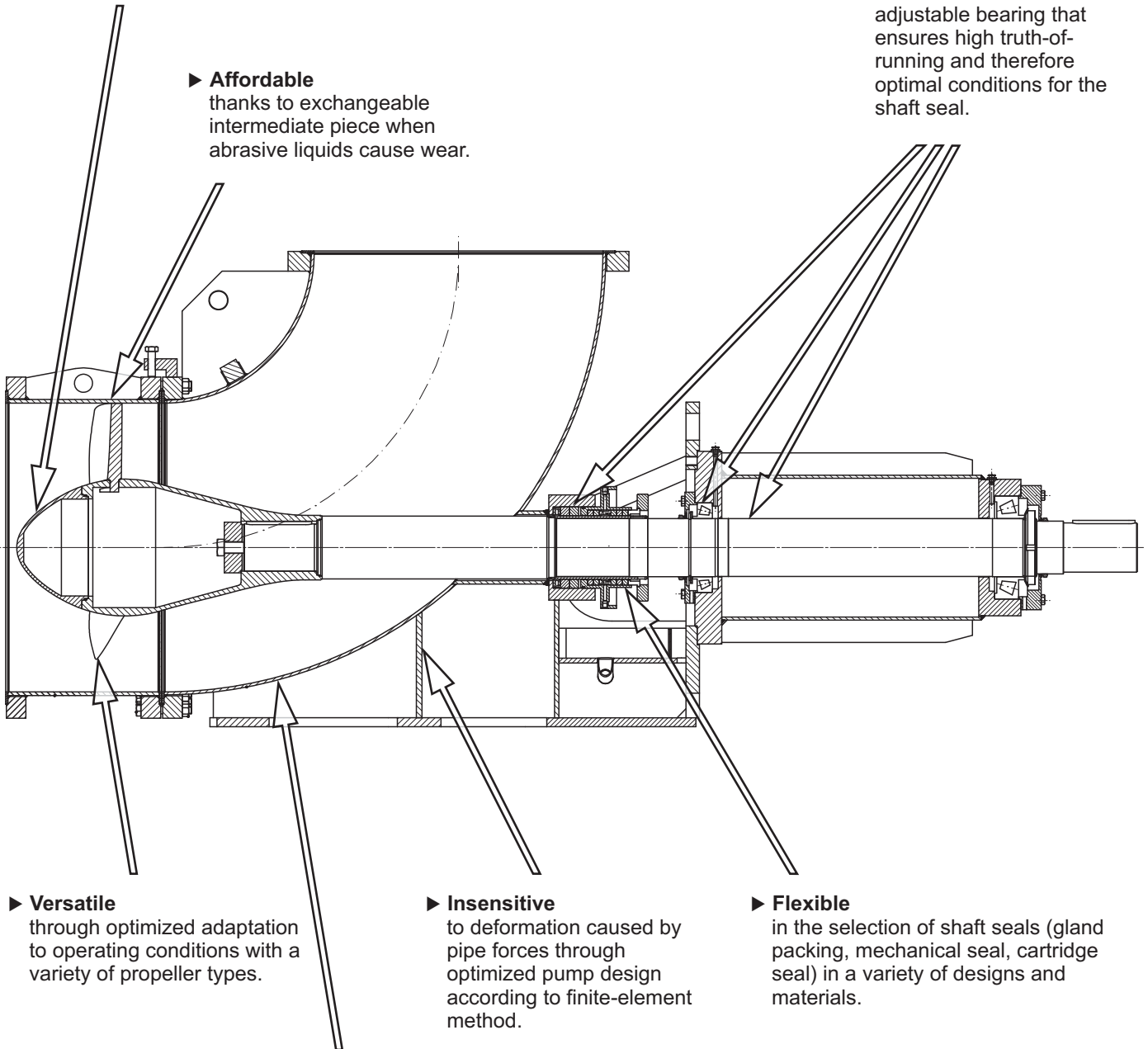

► **Versatile**
through optimized adaptation
to operating conditions with a
variety of propeller types.

► **Insensitive**
to deformation caused by
pipe forces through
optimized pump design
according to finite-element
method.

► **Flexible**
in the selection of shaft seals (gland
packing, mechanical seal, cartridge
seal) in a variety of designs and
materials.

► **Efficient**
with a large-radius elbow casing
for low flow losses and no
disturbing edges in the shaft
passage.

Benefits PGE/PGF

► **Efficient**
through flow-optimized hydraulics.

► **Versatile**
in the selection of shaft seals (gland packing, mechanical seal, cartridge seal) in a variety of designs and materials.

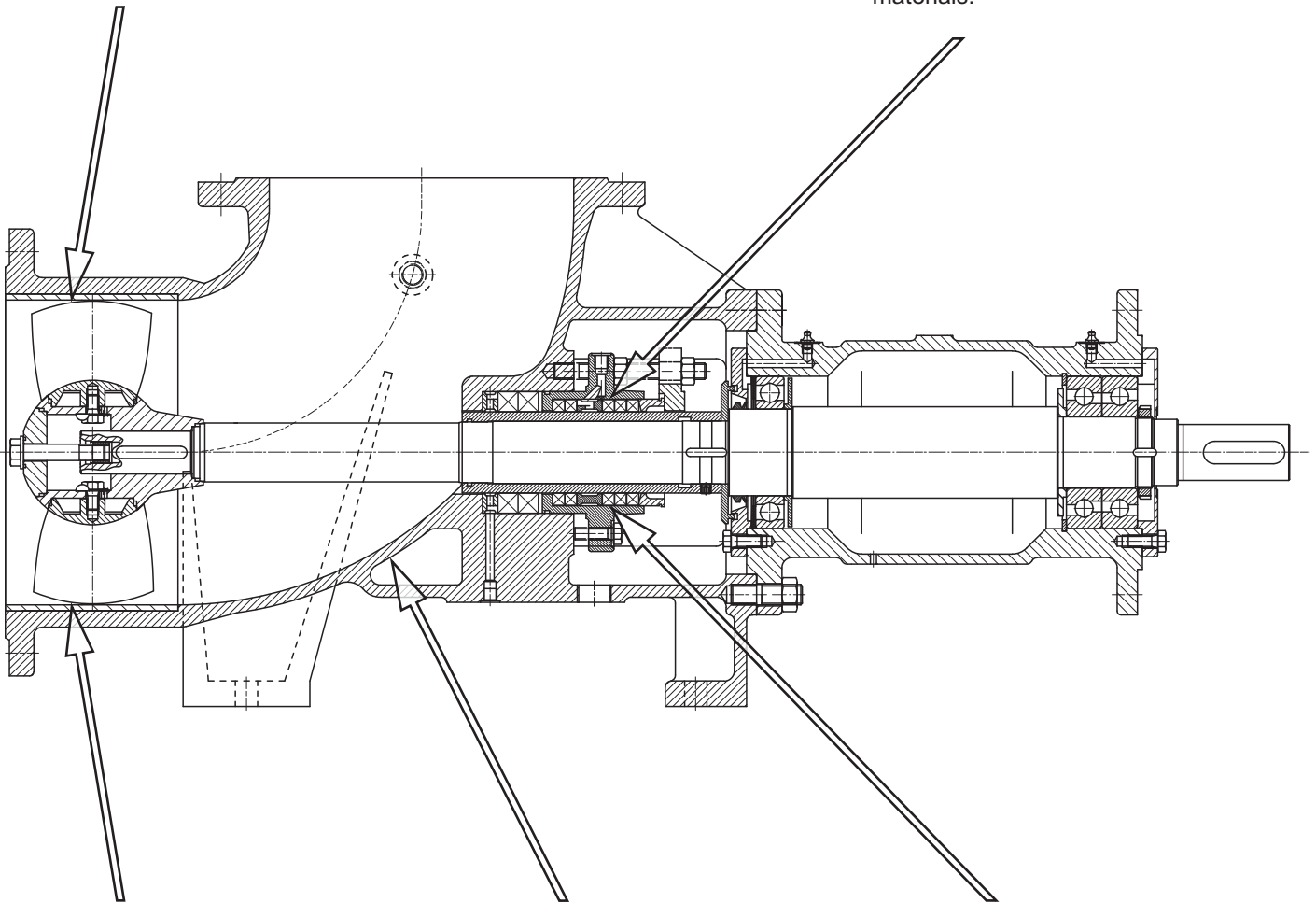

► **Variable**
through optimized adaptation to operating conditions with a variety of propeller types. Special version available with a blade inlet contour that is insensitive to contamination and fibers.

► **Long service life**
through optimized adaptation to operating conditions with an extensive selection of cast materials.

► **Easy maintenance**
Gland packing with stationary gland available, enabling exchange of "operating gland" while pump/system are filled.

Centrifugal Pumps

► Features

Pump capacities acc. to DIN EN 733 or DIN EN 22 858. Additional sizes enlarge the EN-performance range. Series construction acc. to the modular system. Single-stage or multistage pumps in block- or inline-design; pumps with magnetic coupling, pumps for heat transfer oil and hot water.

► Pumped liquids

Neutral or aggressive, pure, with solids content or contaminated, cold or hot, toxic or harmful to the environment.

► Performance data

Q up to 2,400 m³/h, H up to 250 m.

Propeller Pumps

► Features

For large flows at relatively small delivery heads. Horizontal, vertical, submerged and elbow casing pumps.

► Pumped liquids

Neutral or aggressive, pure or contaminated, cold or hot.

► Performance data

Q up to 50,000 m³/h, H up to 20 m.

Self-Priming Side Channel Pumps

► Features

Self-priming side channel segmental-type pumps.

► Pumped liquids

Neutral or aggressive, pure or contaminated, cold or hot, toxic, harmful to the environment.

► Performance data

Q up to 35 m³/h, H up to 350 m.

Three-Screw Pumps

► Features

Three-screw, self-priming, very good efficiencies, very low noise level. The pumping process is continuous, nearly without pulsation and without turbulences. Self-priming, for horizontal and vertical installation, submerged pumps and pumps with magnetic drive.

► Pumped liquids

Oils or other lubricating, not lubricating or sparingly lubricating liquids.

► Performance data

Q up to 7,500 l/min, p_d up to 280 bar.

Two-Screw Pumps

► Features

Two-screw, double-entry, self-priming, high suction power due to low NPSH-values, adapted for dry running.

► Pumped liquids

Oils or other lubricating, not lubricating or sparingly lubricating liquids.

► Performance data

Q up to 1,300 m³/h, p_d up to 40 bar.

Progressing Cavity Pumps

► Features

Single-stage or multistage, self-priming. The pumping is continuous, nearly without pulsation and without turbulences, crushing or demixing.

► Pumped liquids

For pumping and dosing liquids of low to high viscosity; pasty, neutral or aggressive, pure or abrasive, gaseous or tending to froth, also with fibrous and so-lids content.

► Performance data

Q up to 7,500 l/min, p_d up to 36 bar.

Rotary Lobe Pumps

► Features

Hermetically sealed pumps with no welded parts, sealing systems adapted to the liquid, sterile cleaning possible.

► Pumped liquids

For pumping and dosing liquids of low to high viscosity; pasty, neutral or aggressive, pure or abrasive, especially in the food and pharma industry.

► Performance data

Q up to 1,666 l/min, p_d up to 20 bar.

Peristaltic Pumps

► Features

Dry self-priming, without seals and valves.

► Pumped liquids

For pumping and dosing liquids of low to high viscosity; pasty, neutral or aggressive, pure or abrasive, gaseous or tending to froth, also with fibrous and solids content.

► Performance data

Q up to 60 m³/h, p_d up to 16 bar.

Macerators

► Features

Impeller with exchangeable, highly wear resistant milling cutters.

► Pumped liquids

For milling of fibres and solids (wood, textiles, glass etc.) that are contained in the liquids to be pumped and making them pumpable.

► Performance data

Q up to 160 m³/h, p_d up to 10 bar.

Successful in important branches

Decades of experience and branch-specific know-how ensure solutions that are practical and dependable. In addition to individual units with a motor or with a free shaft end, you can get complete systems and customer-specific cast parts from ALLWEILER AG. You are not just investing in machines with ALLWEILER AG. You are also profiting from decades of know-how about applications and processes in your branch.

You will find pumps and systems by ALLWEILER AG in the following sectors:

► Marine and Offshore

Made of particularly corrosion-resistant, saltwater-proof materials and in accordance with specific standards (shock testing, national marine, international classifications etc.).

► Power Generation

Block and twin units for fuel and water injection in gas and steam turbines.
For fuel supply, injection and lubricating oil supply in power plants.

► Water and Wastewater

Pumps for water treatment (dry substance up to 45 %), macerators, which make it possible to pump liquids that are high in fibre and solids.

► Bioenergy

Materials resistant to aggressive intermediate and final products. Pumps for every step in the process.

► Process Engineering and Chemical Industry (ATEX-conformity)

Shaft bearing, shaft seal and material designs in accordance with the chemical characteristics of the pumped liquid. Magnetic coupling for hermetically sealed pumps.

► Oil and Gas

Pumps with a wide viscosity range, high pressure and large capacity.

► Building Industry

Special units for oil furnace and lift systems. Oil submersible pumps for all types of hydraulic machines.

► Food and Pharmaceutical

Stainless steel pumps with CIP and SIP design, EHEDG and FDA certified. Especially for the careful pumping and dosing of even sticky, pasty and solids-rich liquids.

► Machine Tool

Designed for large capacity or a high discharge pressure; resistant to contaminants and foreign matters. Especially for cooling lubricant supply.

► Pulp and Paper

Pumps with extremely high availability (24 hours; 365 days) and many sizes, starting with small dosing pumps and ranging to large kaolin feeding pumps.

► Heat Transfer

In supply circuits, circulating systems and heating circuits for pumping of hot water and heat transfer oil up to 207 °C and 450 °C.

Subject to technical alterations.